

20D Metal Gearmotors

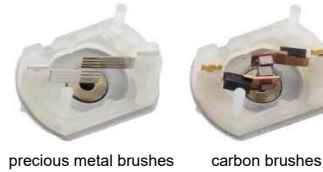

Pololu 20D Metal Gearmotors are available in 12 different gear ratios, from 25:1 up to 488:1, and with three different motor options:

- **6V**: 6 V windings with precious metal brushes
- **6V CB**: 6 V windings with long-life carbon brushes
- **12V CB**: 12 V windings with long-life carbon brushes



The **12V CB** versions offer approximately the same speed and torque performance at 12 V as their **6V CB** counterparts do at 6 V, just with approximately half the current draw.

Each motor is available with an optional extended rear motor shaft to allow for the addition of an encoder such as Pololu item #3499 Magnetic Encoder Pair Kit. This rear shaft rotates at the same speed as the input to the gearbox.



Dimensions

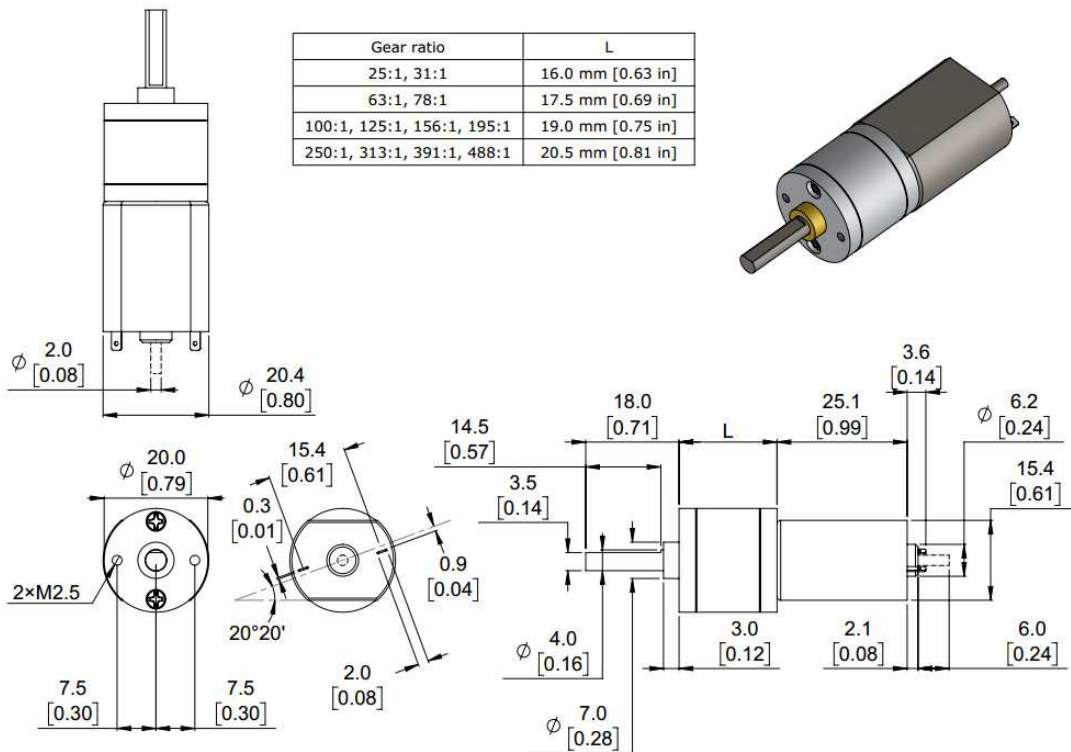

Units are mm over [inches]. Weight ranges from approximately 45 g to 50 g.

20D Metal Gearmotors



Performance summary and table of contents

Motor Type	Rated Voltage	Pololu Item #	Gear Ratio	No Load		At Maximum Efficiency				Max Power	Stall Extrapolation		Graph Page
				Speed	Current	Speed	Torque	Current	Output		Torque	Current	
			:1	RPM	A	RPM	kg-mm	A	W	W	kg-mm	A	
6V CB	6 V	3700, 3712	25	570	0.15	440	3.3	0.74	1.5	2.3	16	2.9	3
		3701, 3713	31.25	450		360	3.9	0.65	1.4	2.3	20		4
		3702, 3714	62.5	230		190	7.1	0.61	1.4	2.4	40		5
		3703, 3715	78.125	180		150	7.6	0.59	1.2	2.1	44		6
		3704, 3716	100	140		120	10	0.63	1.1	2.0	54		7
		3705, 3717	125	110		93	12	0.62	1.1	1.9	64		8
		3706, 3718	156.25	91		74	14	0.60	1.1	1.8	79		9
		3707, 3719	195.31	73		60	17	0.61	1.0	1.7	94		10
		3708, 3720	250	57		47	21	0.62	1.0	1.8	120		11
		3709, 3721	312.5	45		38	24	0.61	0.93	1.6	130		12
		3710, 3722	390.63	36		30	27	0.60	0.84	1.4	160		13
		3711, 3723	488.28	30		24	35	0.61	0.89	1.3	210		14
		3474, 3486	25	550		440	3.4	0.35	1.6	2.6	19		15
		3475, 3487	31.25	450		360	4.4	0.35	1.7	2.8	24		16
3476, 3488	62.5	220	180	8.0	0.32	1.5	2.6	46	17				
3477, 3489	78.125	180	150	9.3	0.33	1.4	2.5	54	18				
3478, 3490	100	140	120	10	0.31	1.2	2.2	61	19				
3479, 3491	125	110	94	13	0.31	1.2	2.2	78	20				
3480, 3492	156.25	89	75	15	0.30	1.1	2.0	90	21				
3481, 3493	195.31	72	60	17	0.30	1.0	1.9	100	22				
3482, 3494	250	55	47	24	0.33	1.2	2.0	140	23				
3483, 3495	312.5	44	38	26	0.31	1.0	1.8	160	24				
3484, 3496	390.63	36	30	35	0.31	1.1	1.7	210	25				
3485, 3497	488.28	28	24	43	0.32	1.0	1.5	250	26				

Notes:

- 1) Performance data currently unavailable for 20D versions with precious metal brushes (items #3450-3473), but it should generally be similar to the performance of the versions with carbon brushes (**6V CB**) listed in this datasheet.
- 2) Listed stall torques and currents are theoretical extrapolations; units will typically stall well before these points as the motors heat up. Stalling or overloading gearmotors can greatly decrease their lifetimes and even result in immediate damage. The recommended upper limit for continuously applied loads is 50 kg-mm for the versions with carbon brushes (**6V CB** and **12V CB**), and 35 kg-mm for versions with precious metal brushes. Stalls can also result in rapid (potentially on the order of seconds) thermal damage to the motor windings and brushes; a general recommendation for brushed DC motor operation is 25% or less of the stall current.

Pololu Items #3700, #3712 (25:1 Metal Gearmotor 20D 6V CB) Performance at 6 V

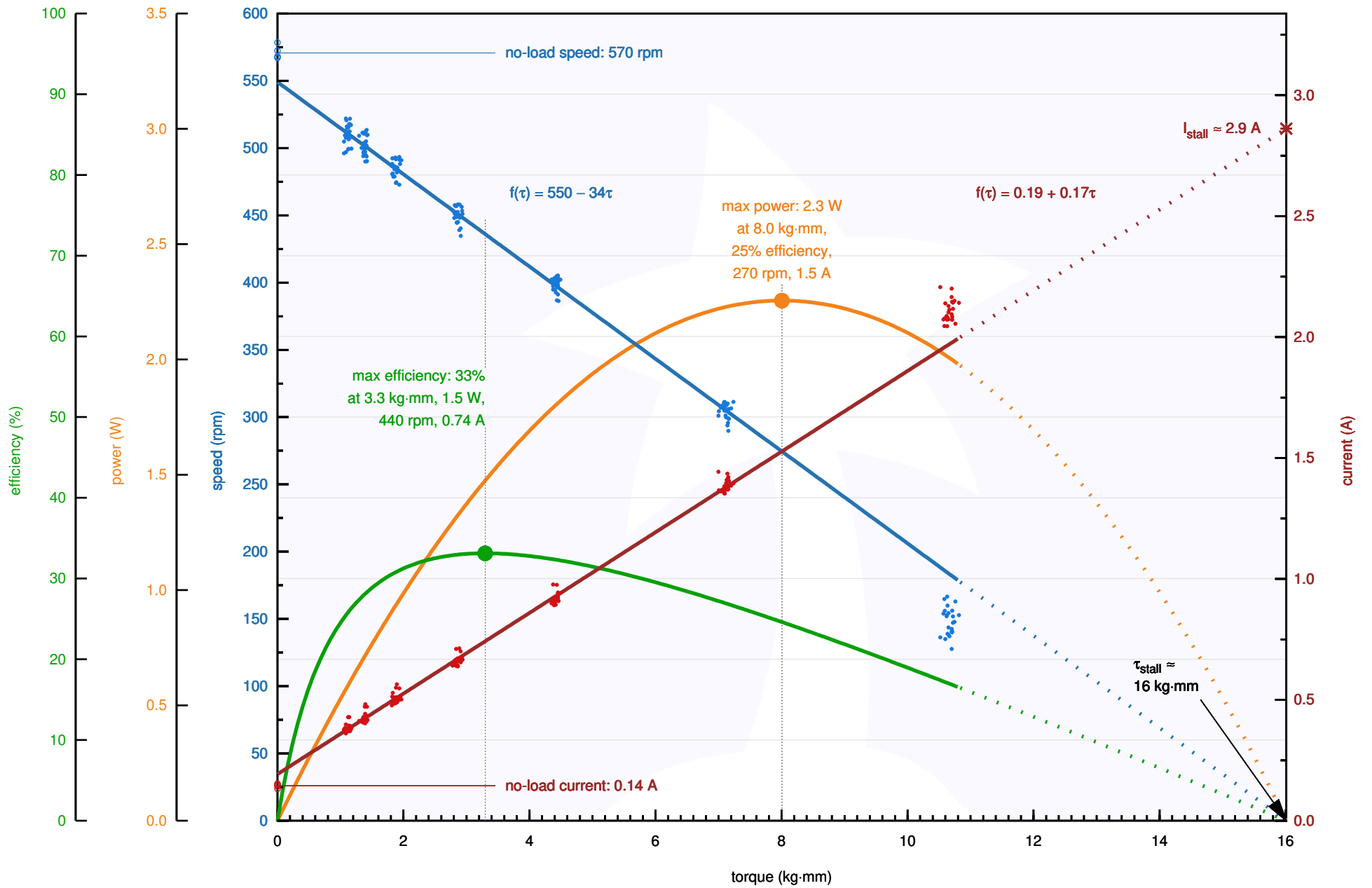

Pololu Items #3701, #3713 (31:1 Metal Gearmotor 20D 6V CB) Performance at 6 V

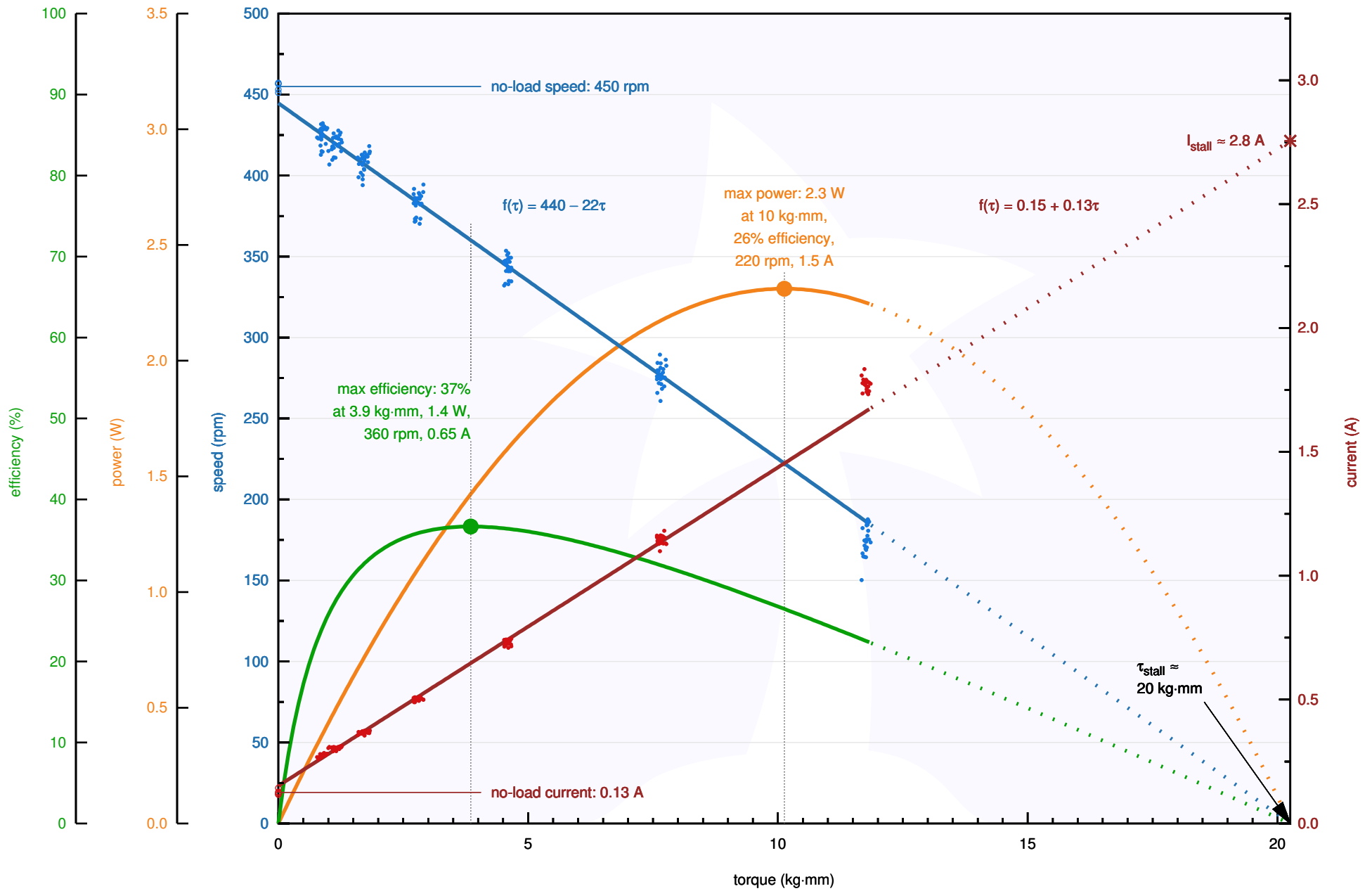

Pololu Items #3702, #3714 (63:1 Metal Gearmotor 20D 6V CB) Performance at 6 V

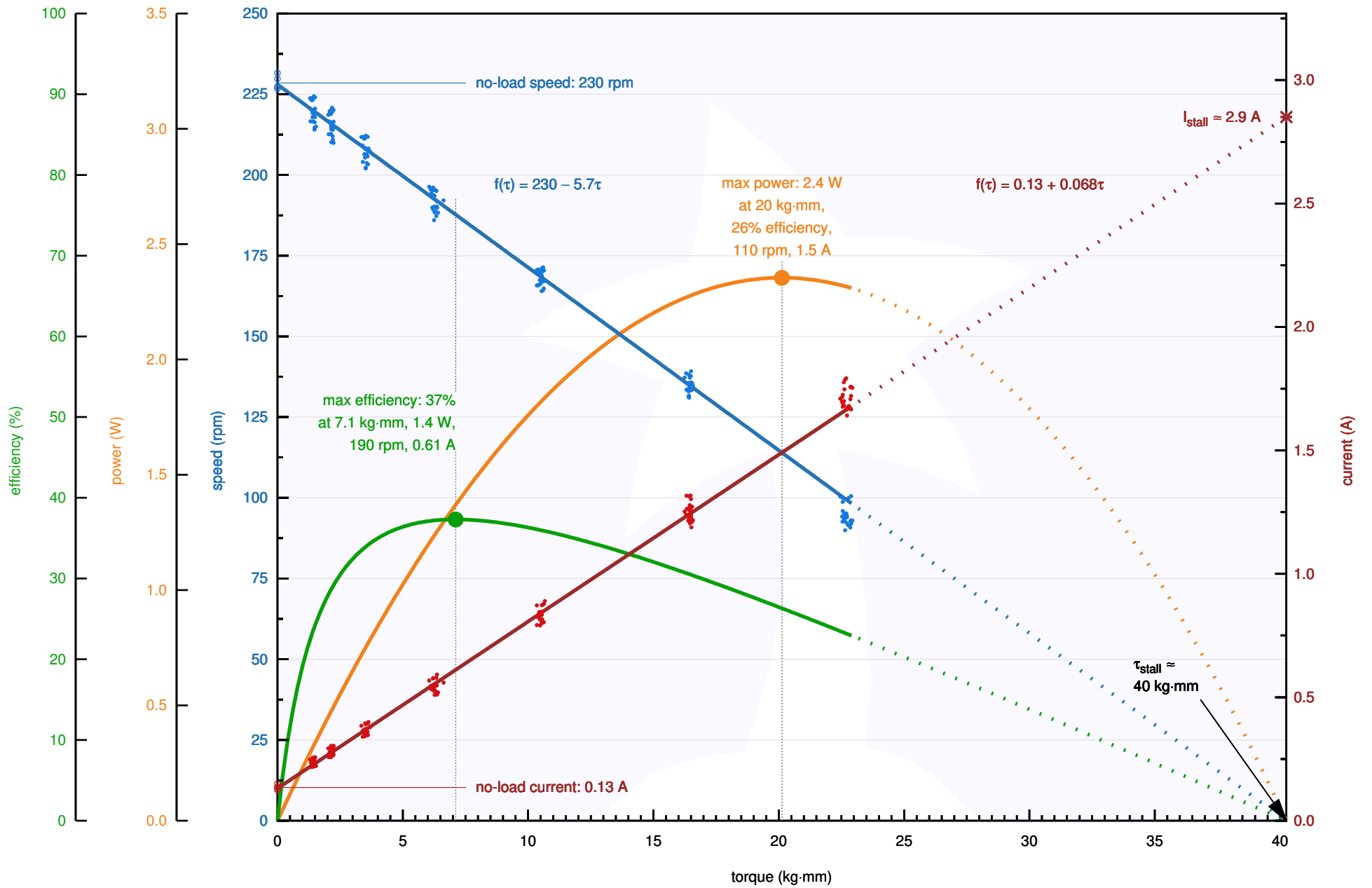

Pololu Items #3703, #3715 (78:1 Metal Gearmotor 20D 6V CB) Performance at 6 V

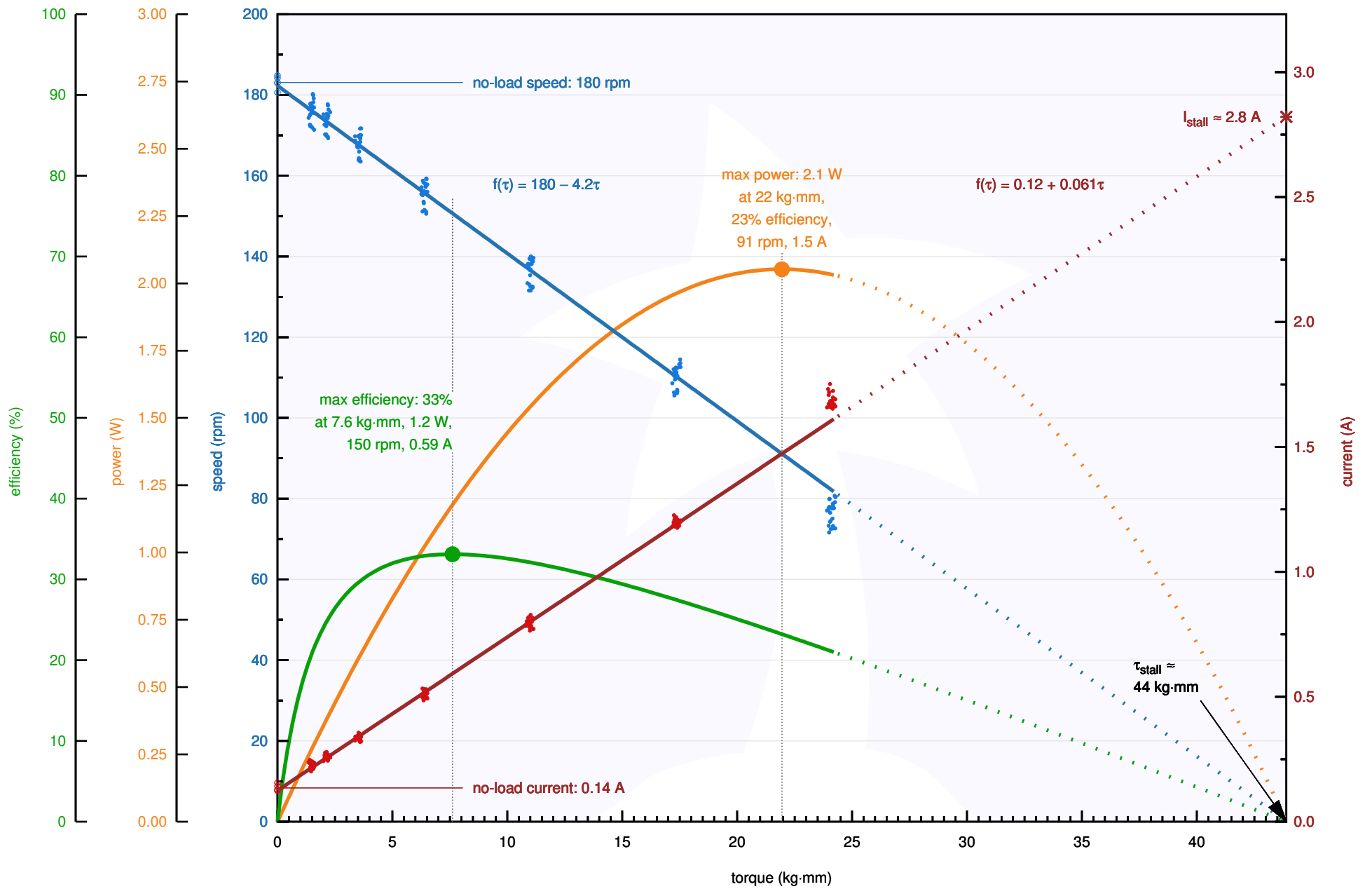

Pololu Items #3704, #3716 (100:1 Metal Gearmotor 20D 6V CB) Performance at 6 V

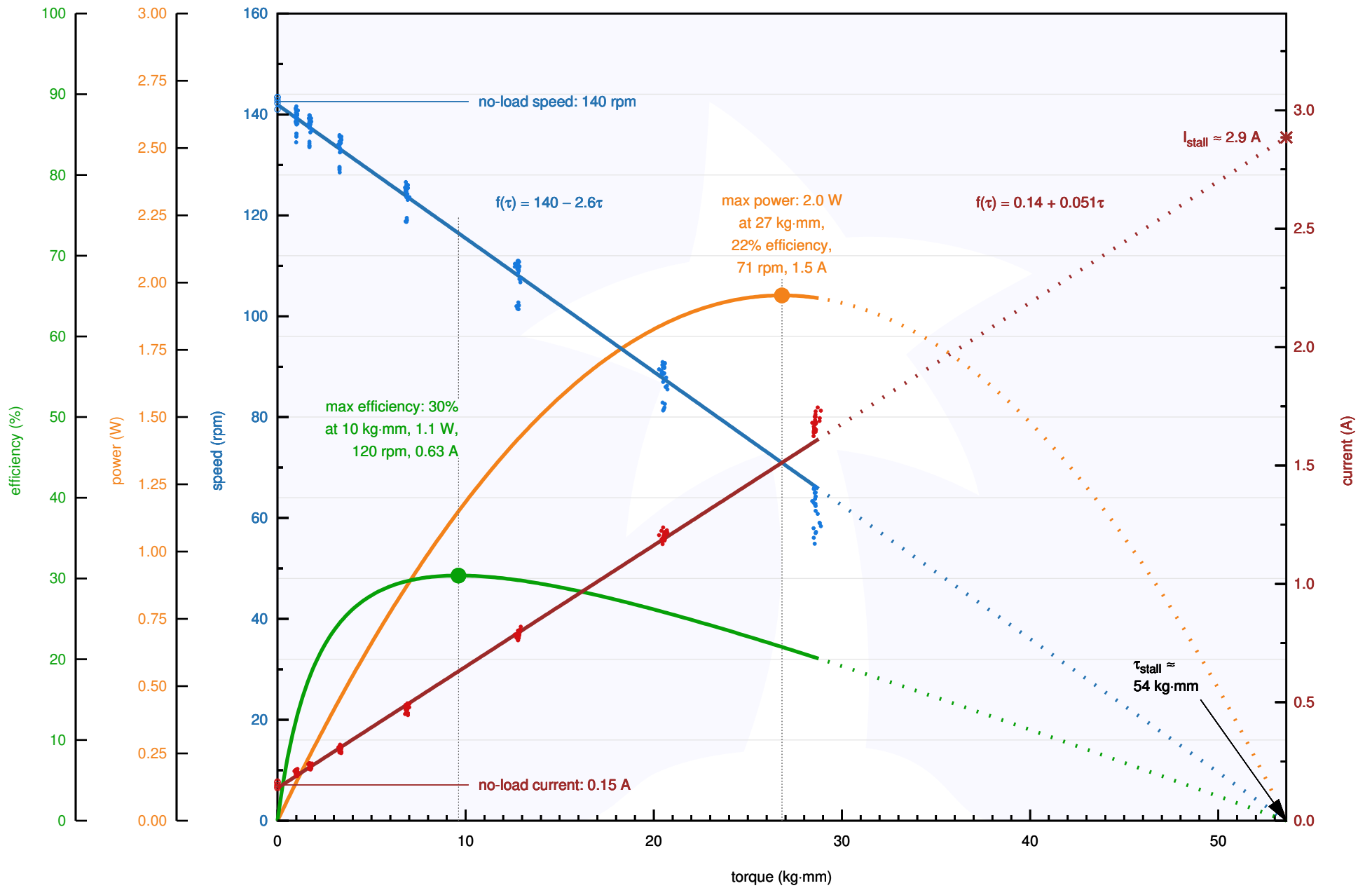

Pololu Items #3705, #3717 (125:1 Metal Gearmotor 20D 6V CB) Performance at 6 V

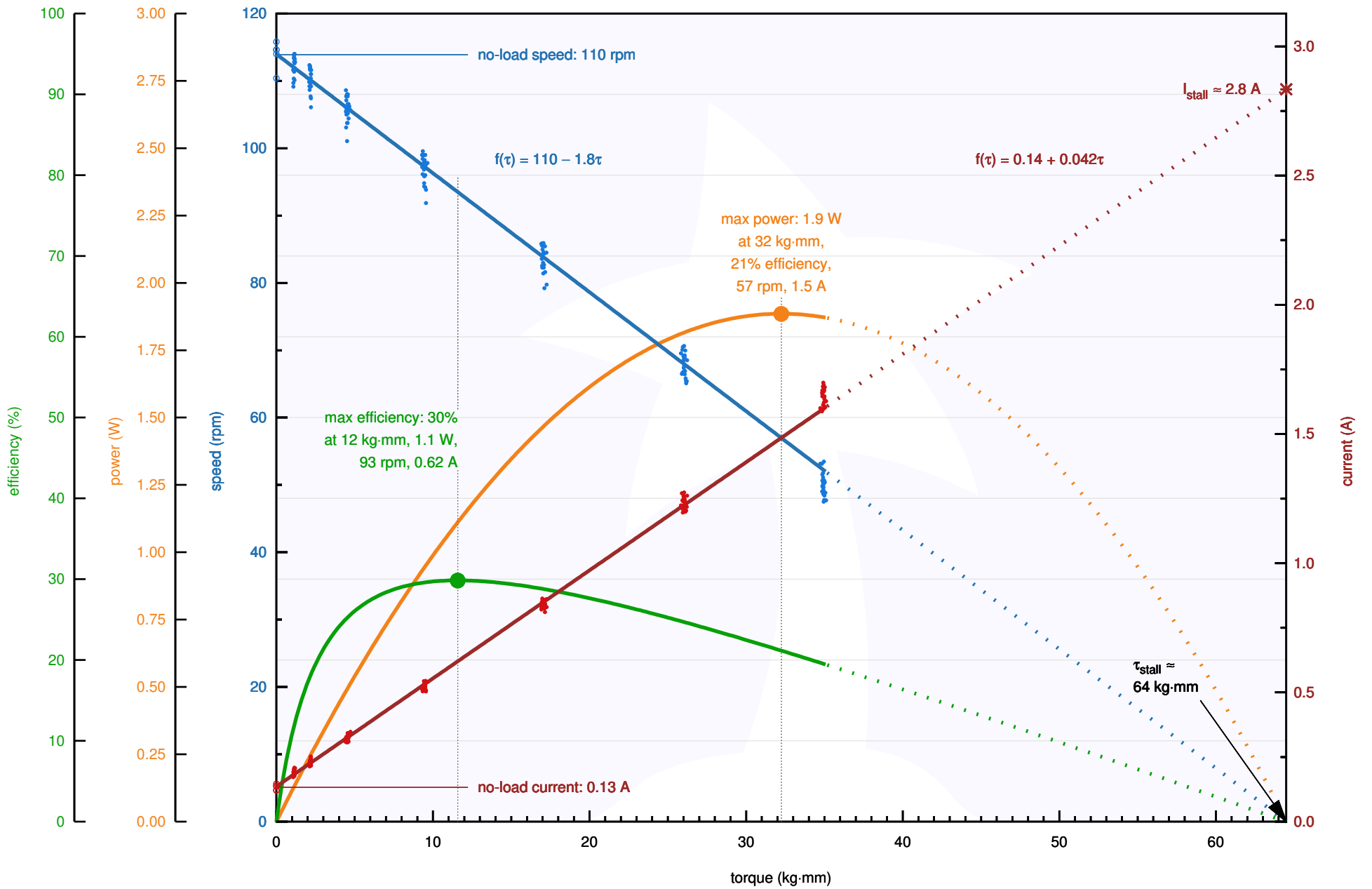

Pololu Items #3706, #3718 (156:1 Metal Gearmotor 20D 6V CB) Performance at 6 V

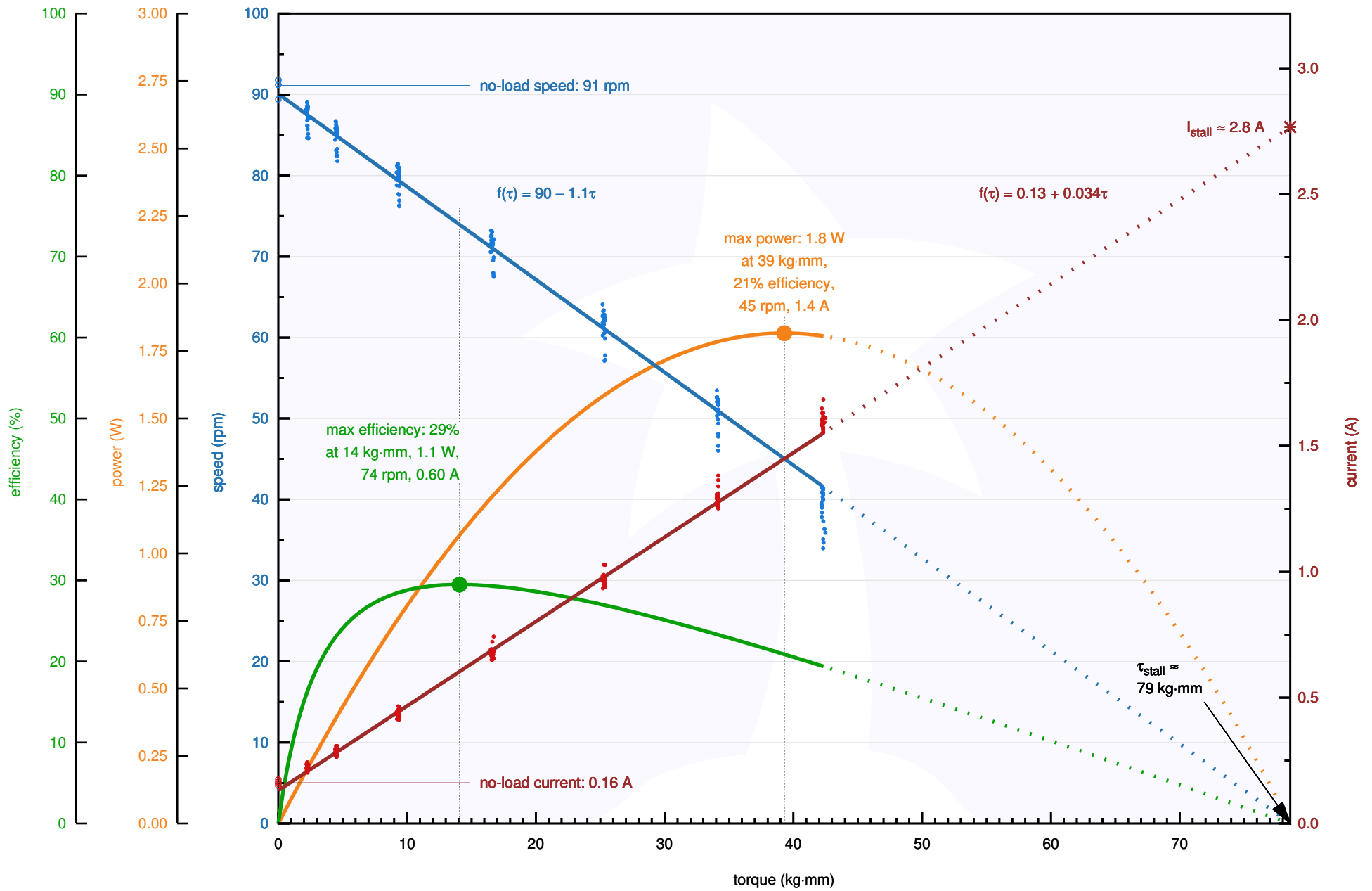

Pololu Items #3707, #3719 (195:1 Metal Gearmotor 20D 6V CB) Performance at 6 V

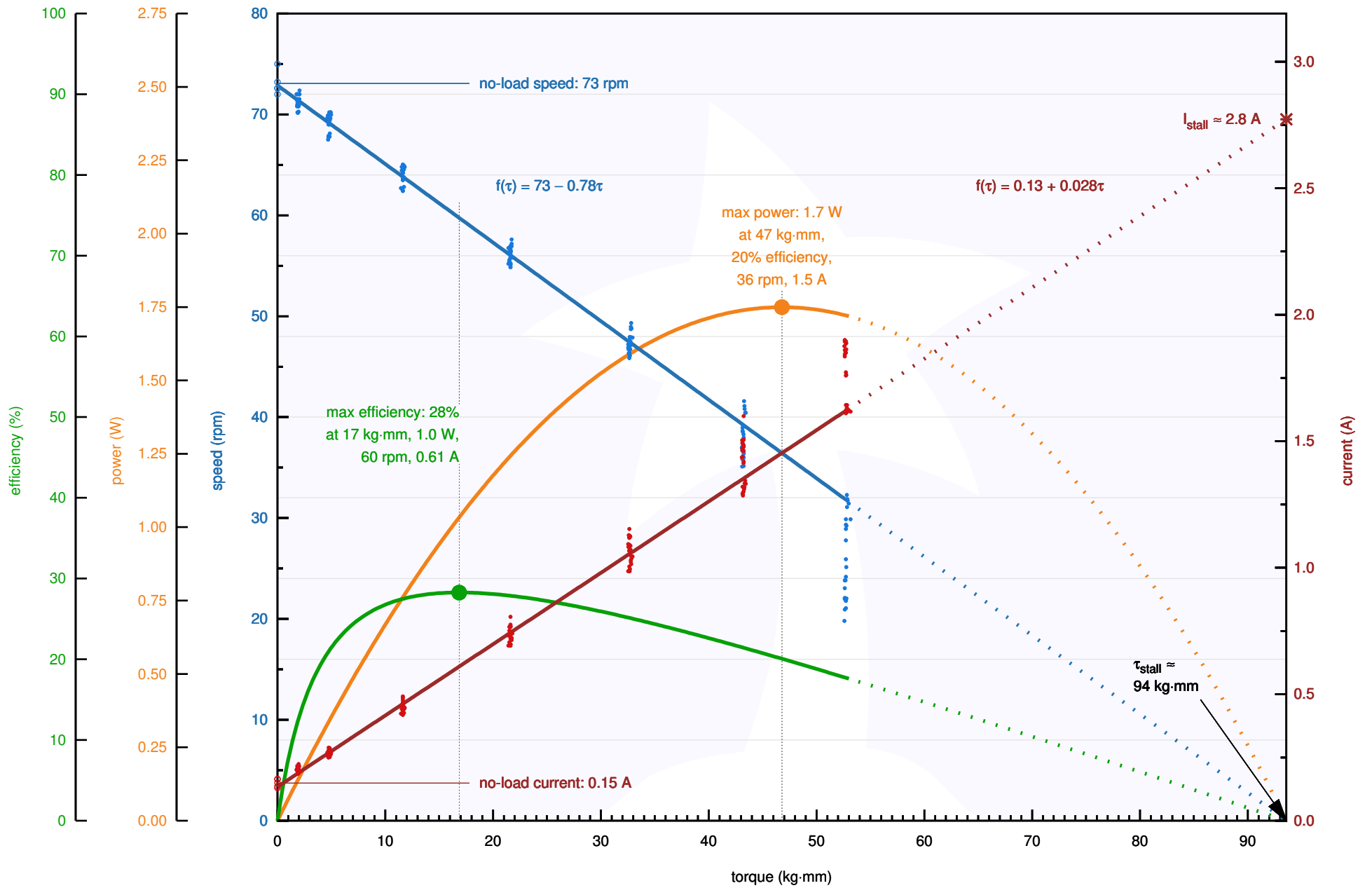

Pololu Items #3708, #3720 (250:1 Metal Gearmotor 20D 6V CB) Performance at 6 V

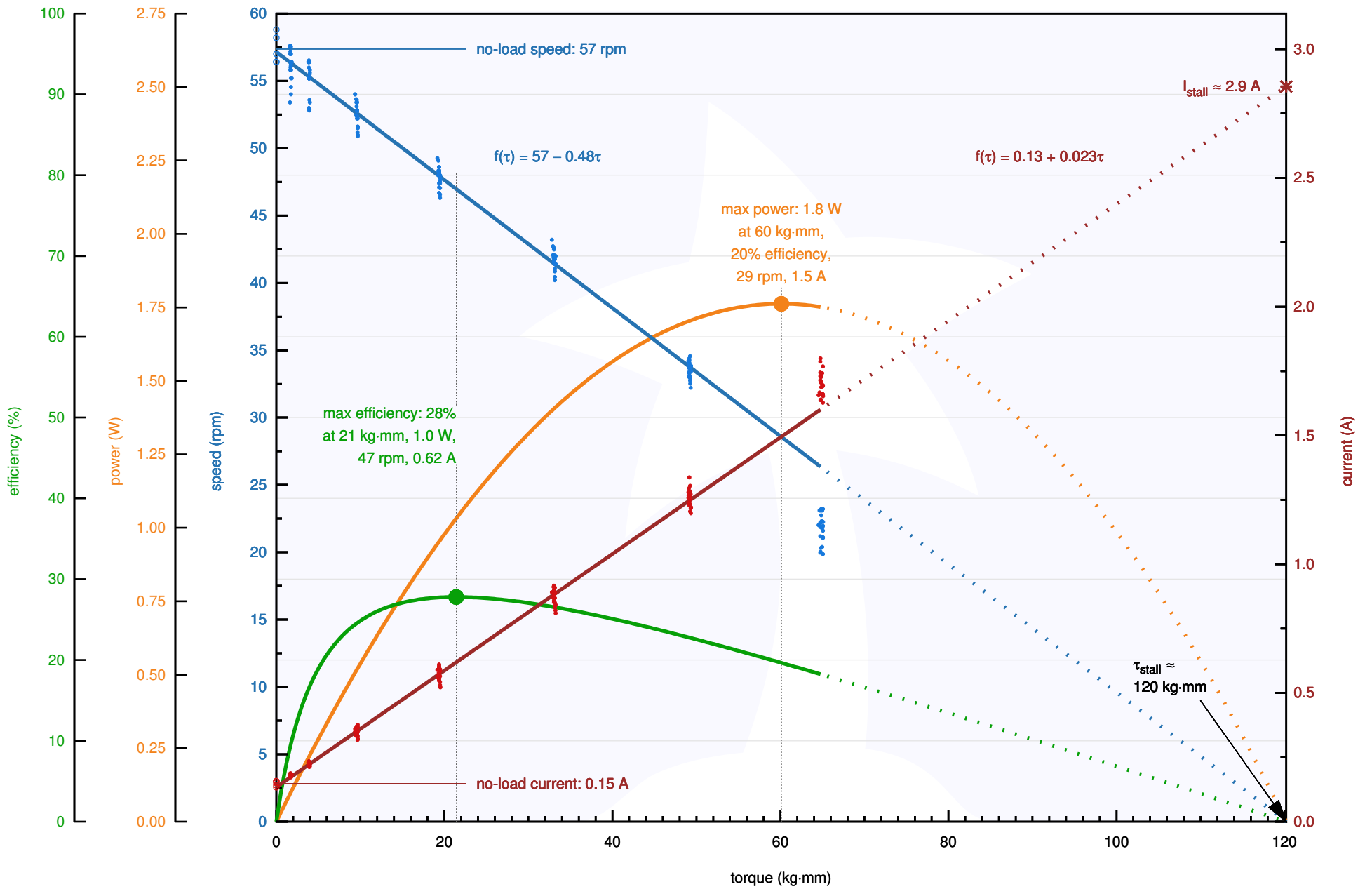

Pololu Items #3709, #3721 (313:1 Metal Gearmotor 20D 6V CB) Performance at 6 V

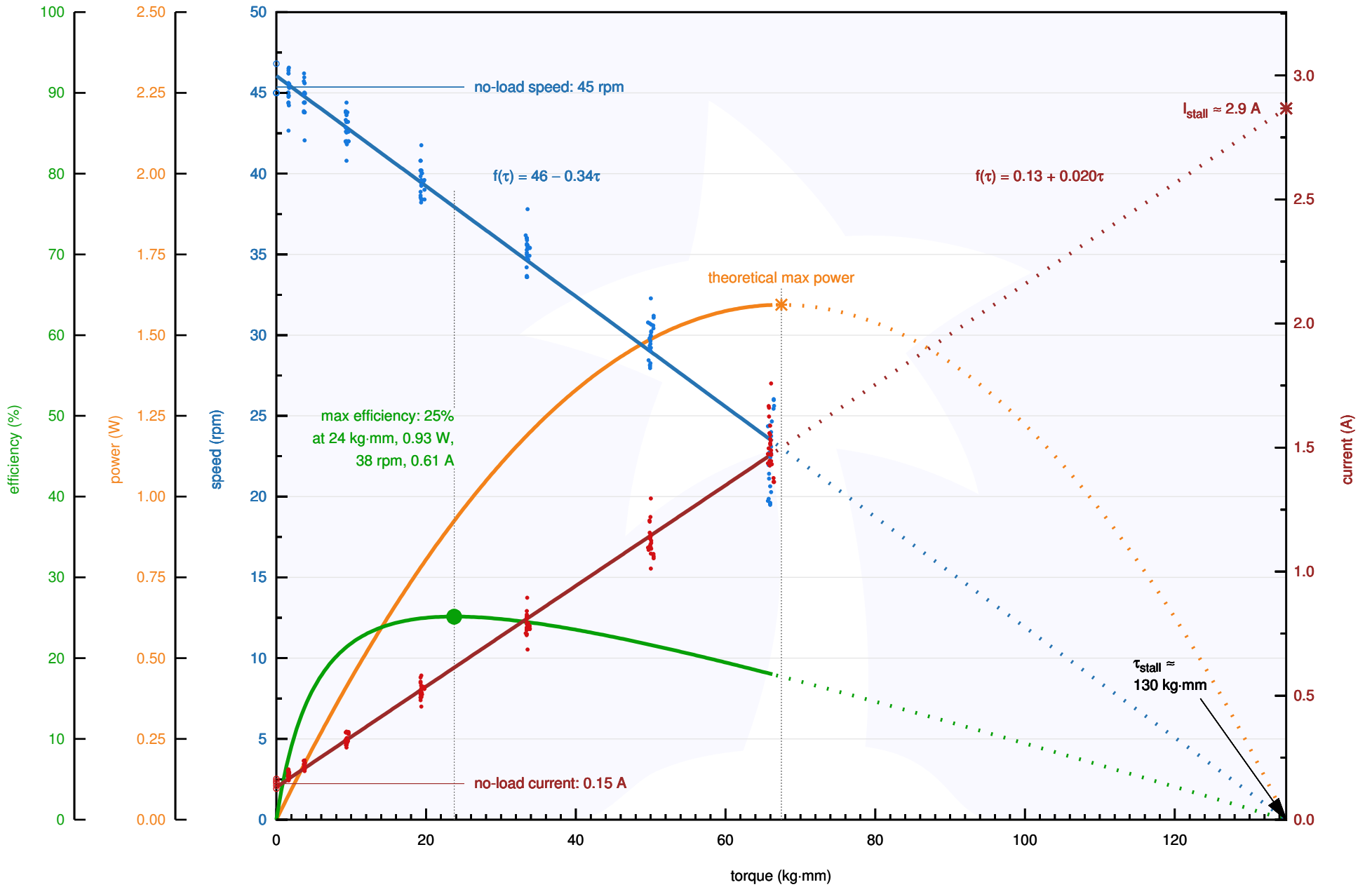

Pololu Items #3710, #3722 (391:1 Metal Gearmotor 20D 6V CB) Performance at 6 V

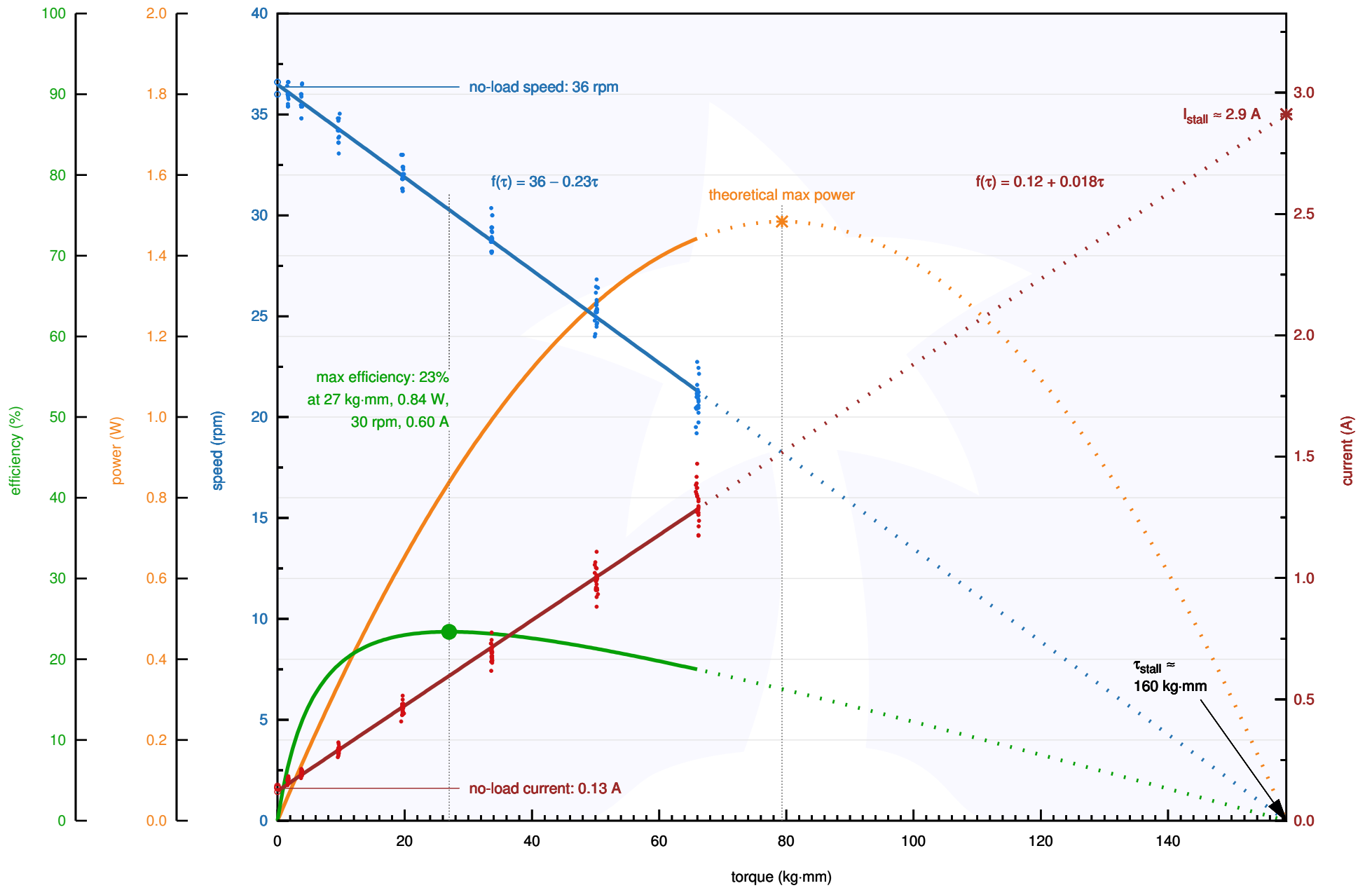

Pololu Items #3711, #3723 (488:1 Metal Gearmotor 20D 6V CB) Performance at 6 V

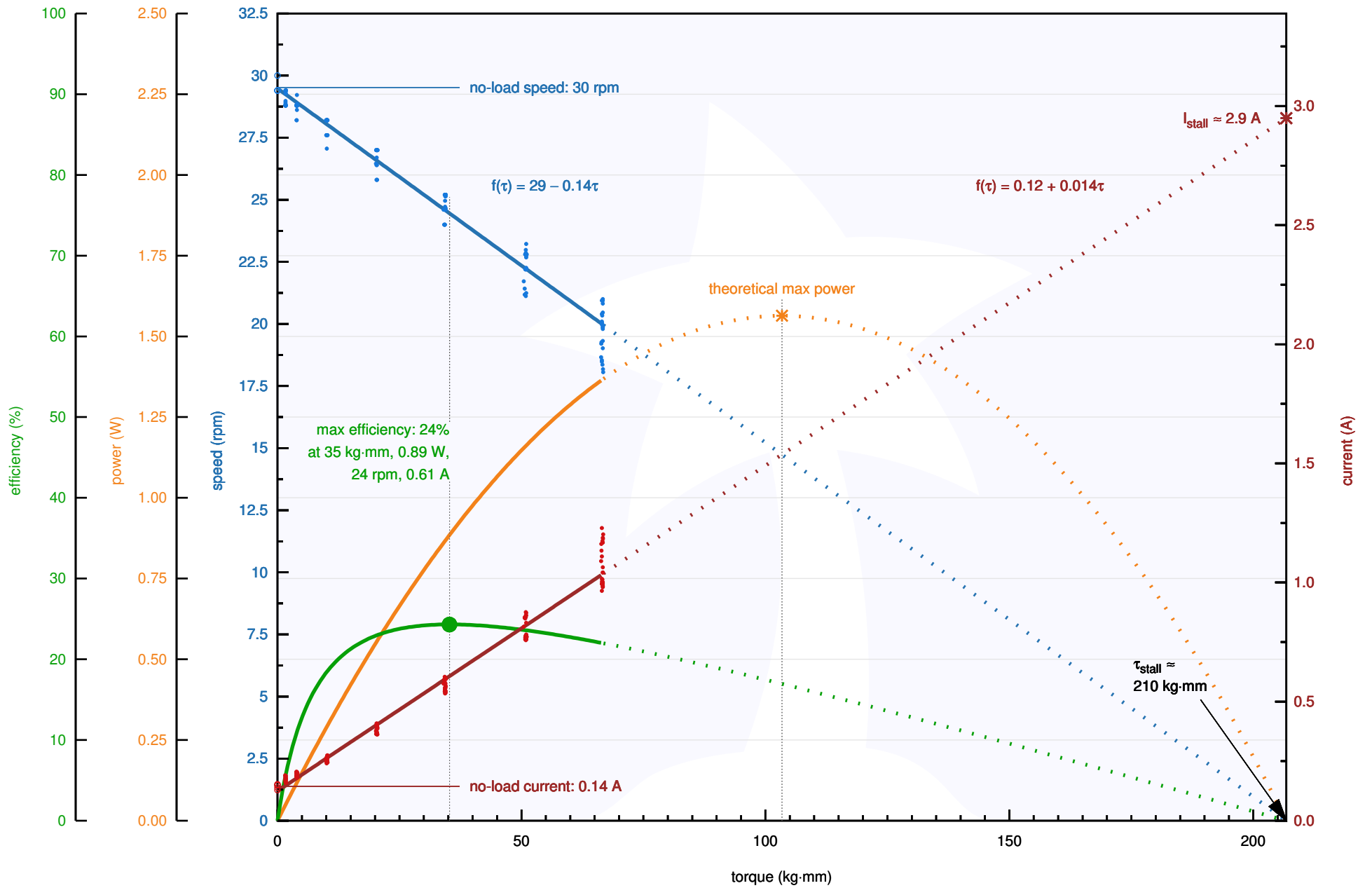

Pololu Items #3474, #3486 (25:1 Metal Gearmotor 20D 12V CB) Performance at 12 V

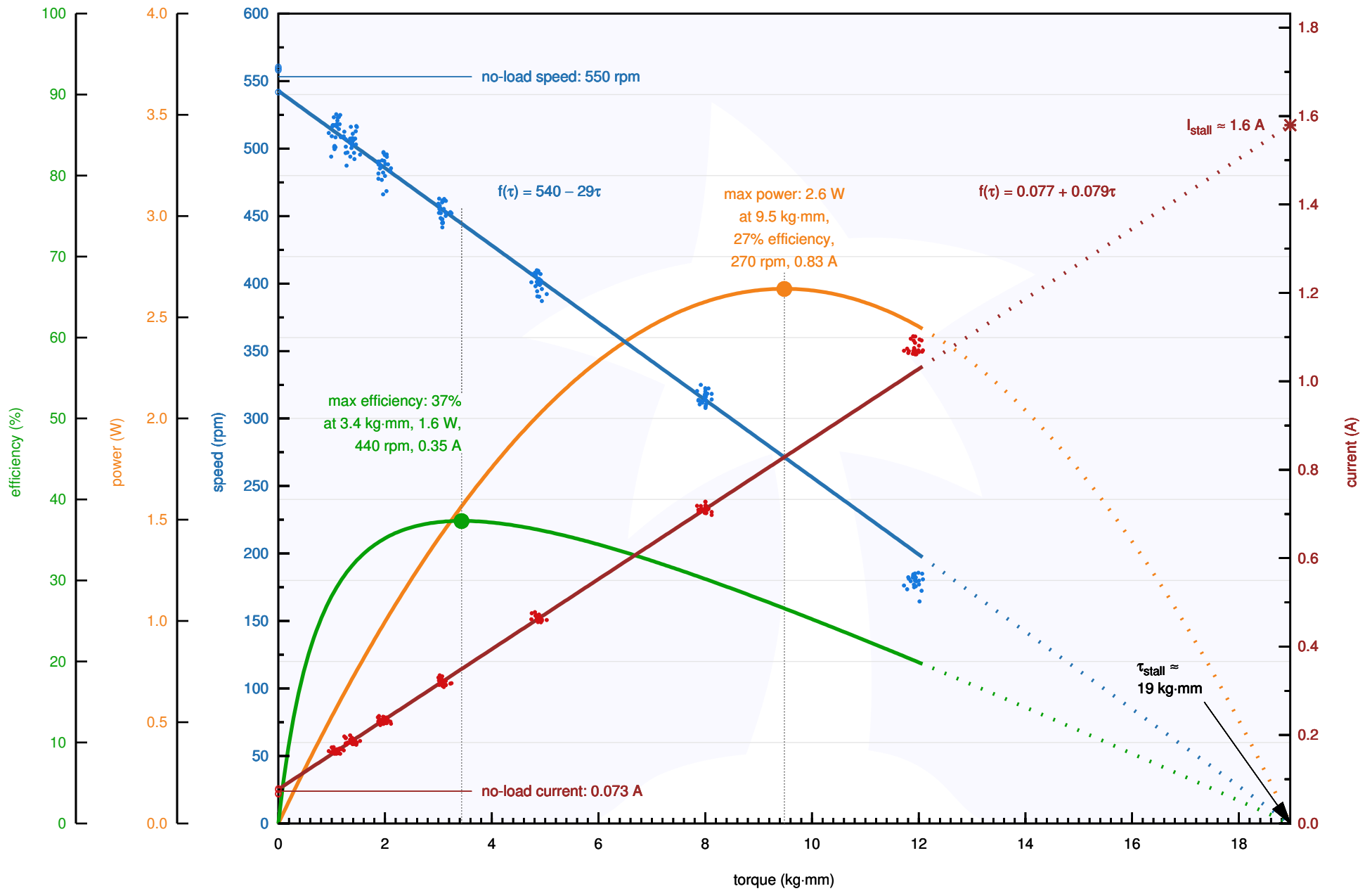

Pololu Items #3475, #3487 (31:1 Metal Gearmotor 20D 12V CB) Performance at 12 V

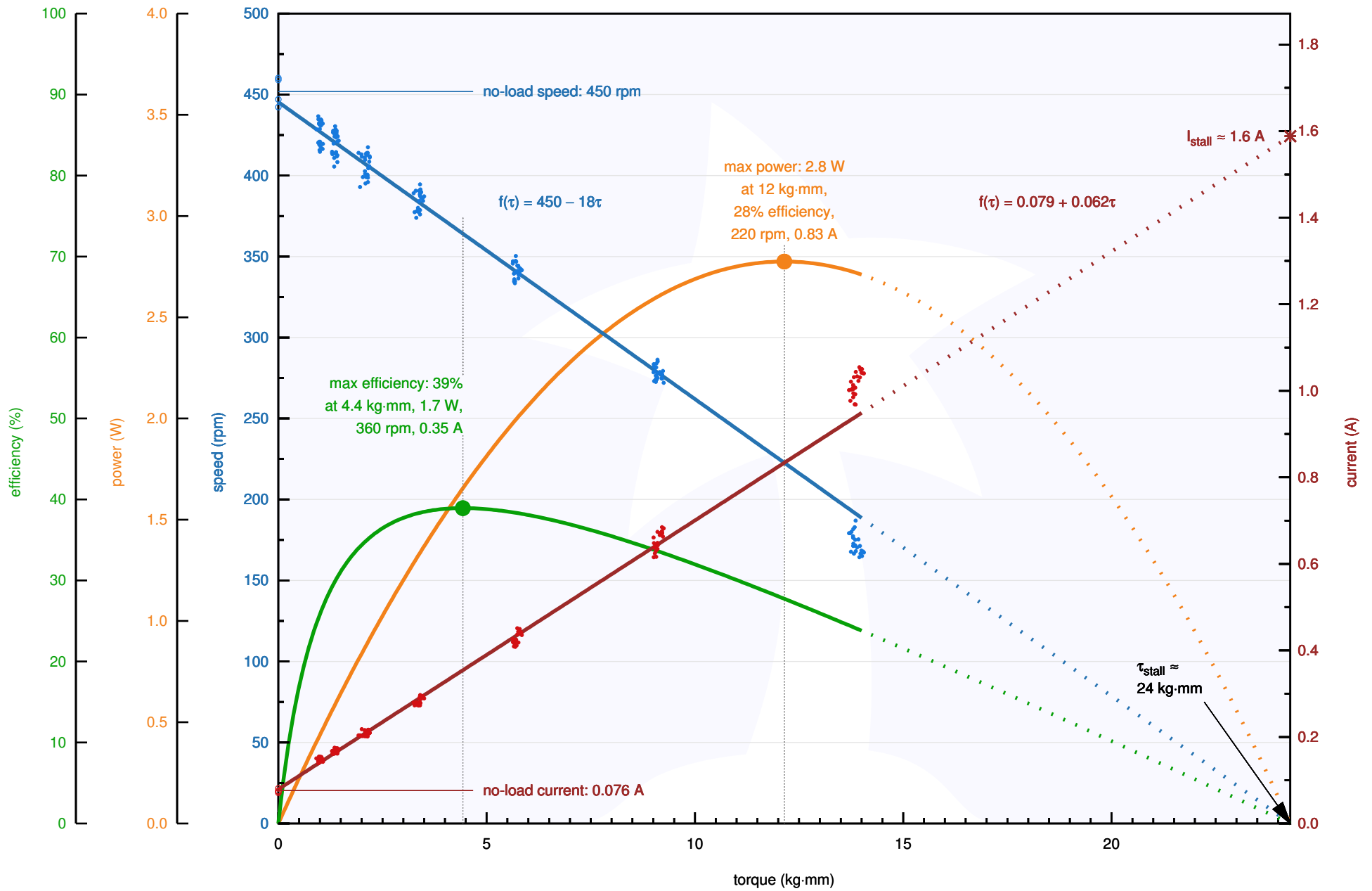

Pololu Items #3476, #3488 (63:1 Metal Gearmotor 20D 12V CB) Performance at 12 V

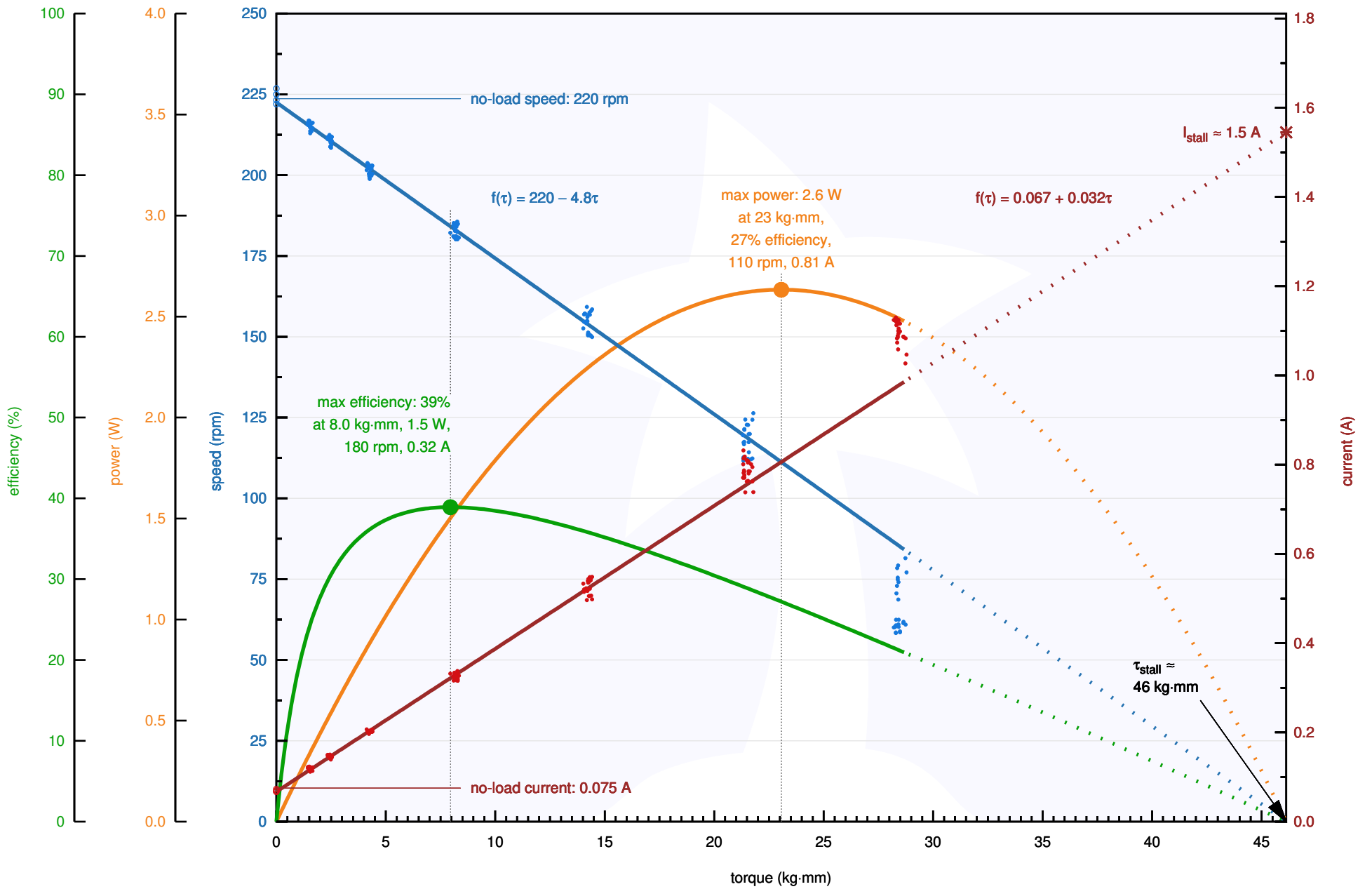

Pololu Items #3477, #3489 (78:1 Metal Gearmotor 20D 12V CB) Performance at 12 V

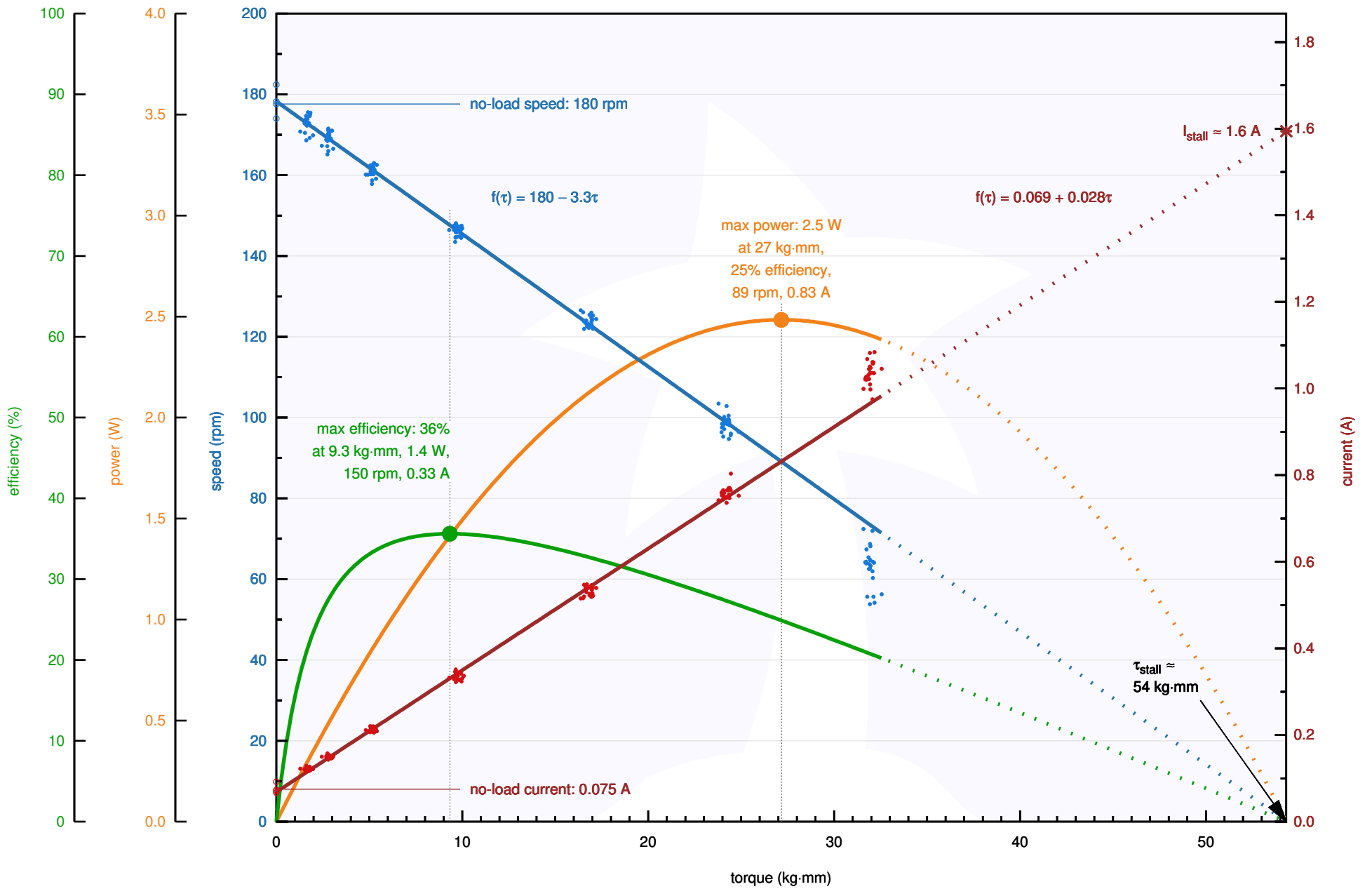

Pololu Items #3478, #3490 (100:1 Metal Gearmotor 20D 12V CB) Performance at 12 V

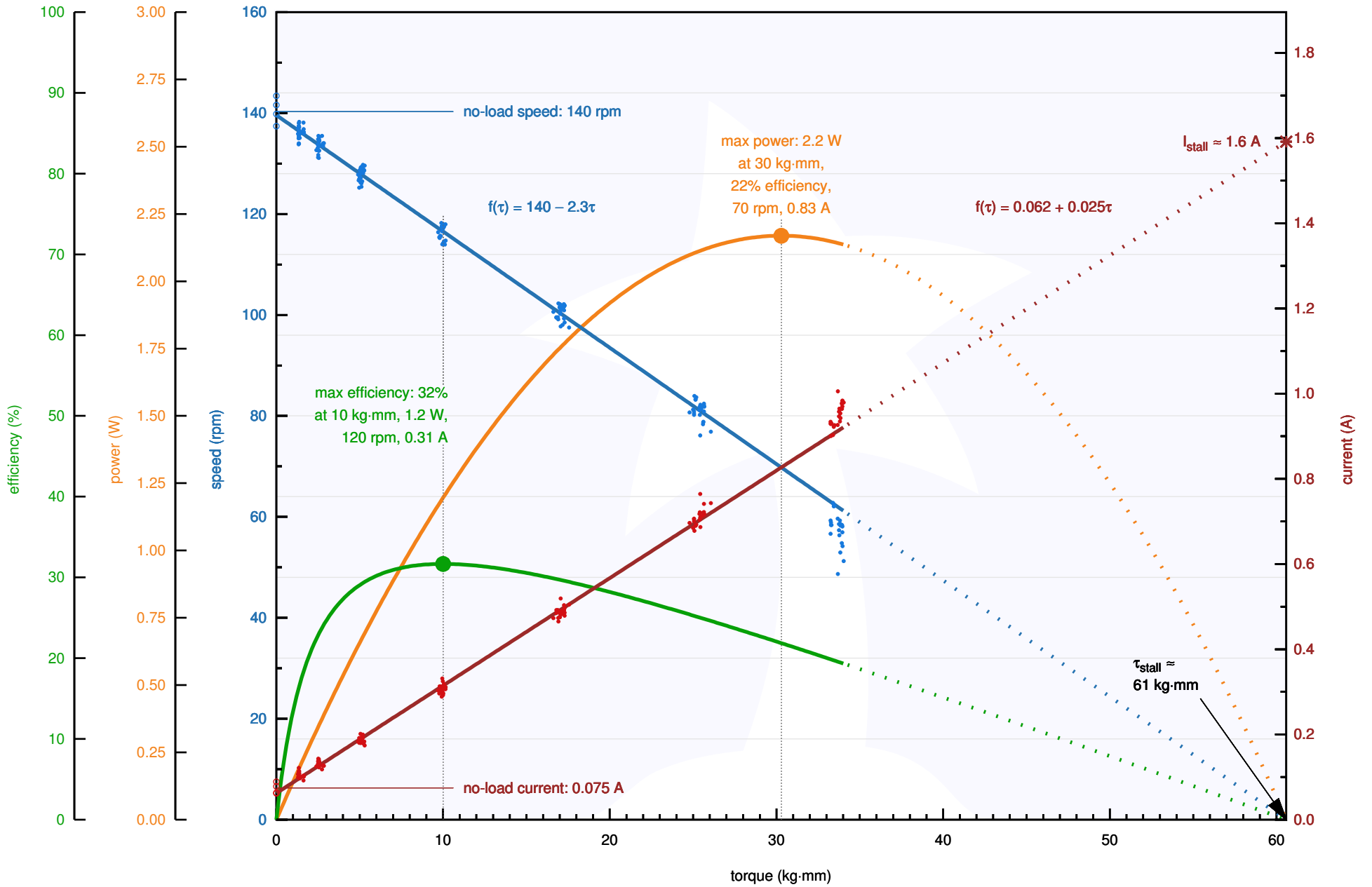

Pololu Items #3479, #3491 (125:1 Metal Gearmotor 20D 12V CB) Performance at 12 V

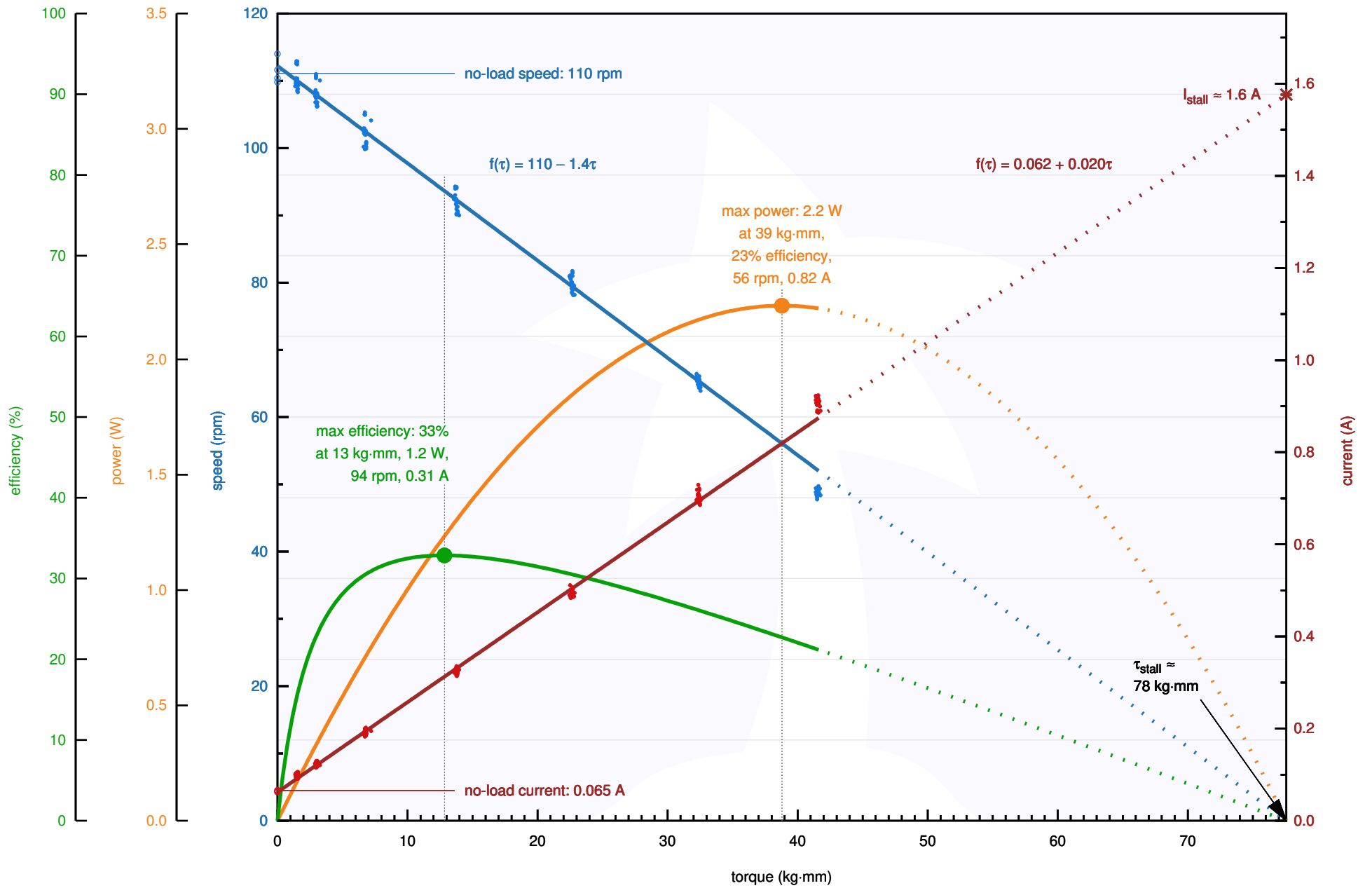

Pololu Items #3480, #3492 (156:1 Metal Gearmotor 20D 12V CB) Performance at 12 V

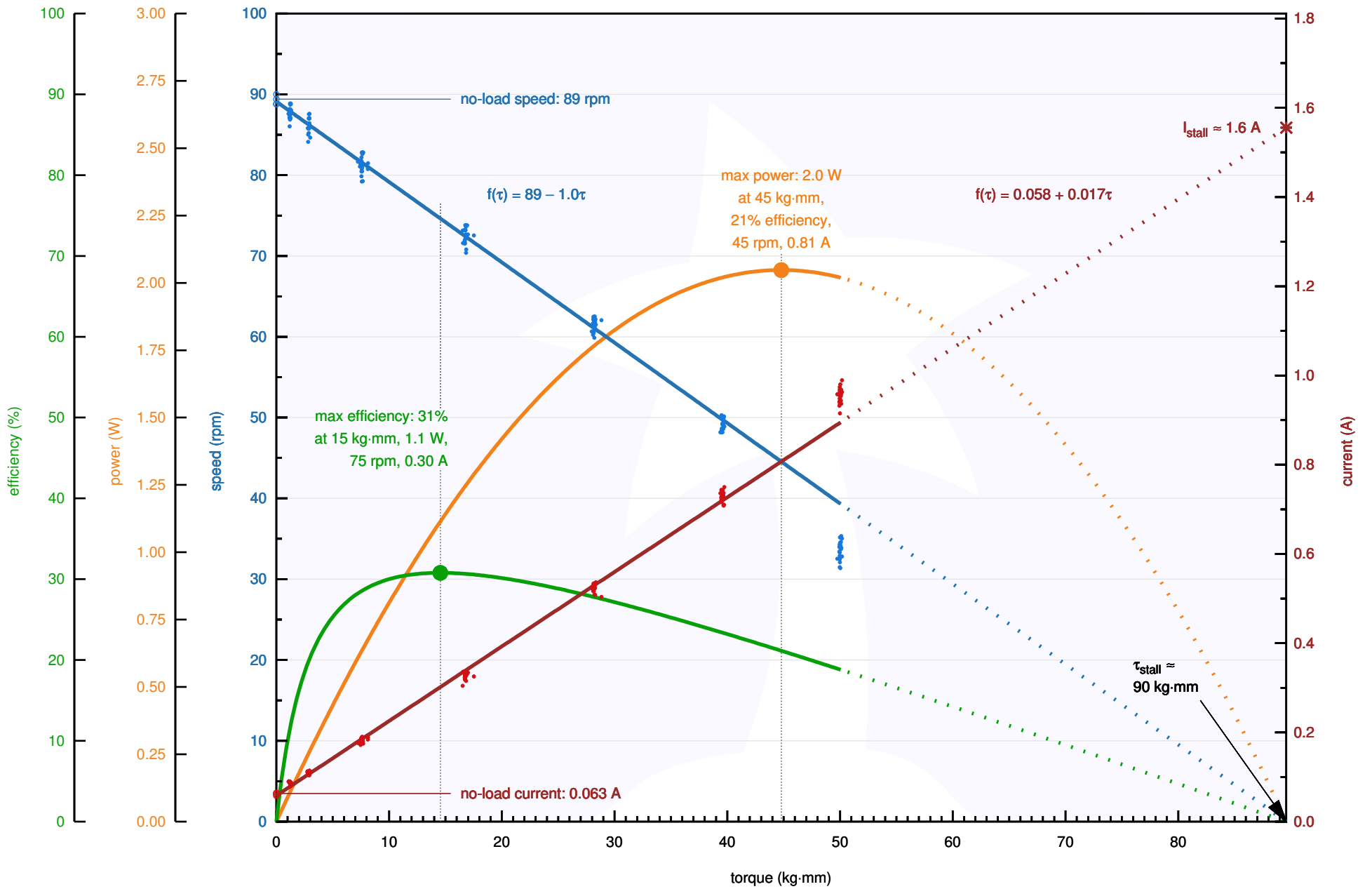

Pololu Items #3481, #3493 (195:1 Metal Gearmotor 20D 12V CB) Performance at 12 V

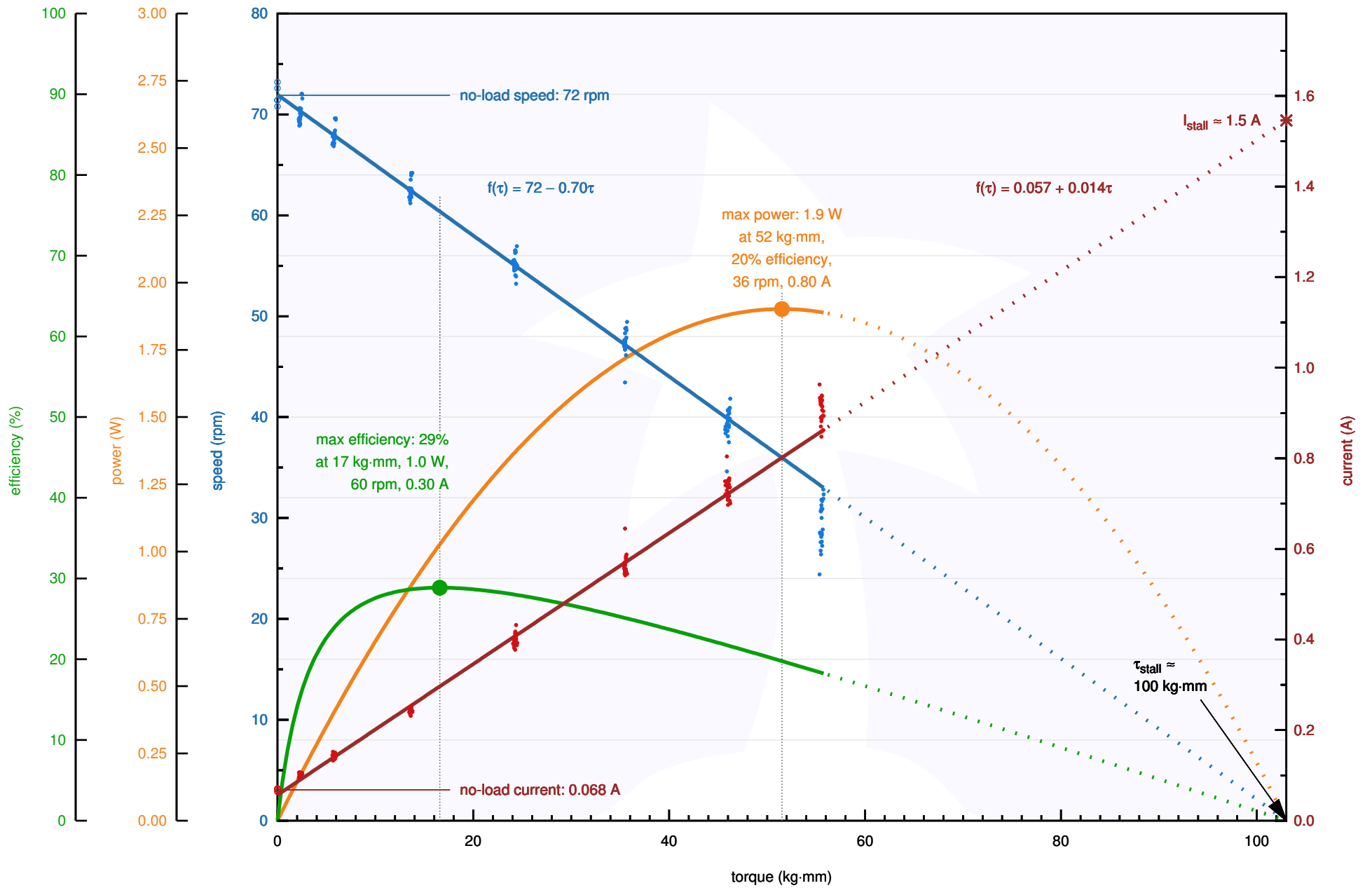

Pololu Items #3482, #3494 (250:1 Metal Gearmotor 20D 12V CB) Performance at 12 V

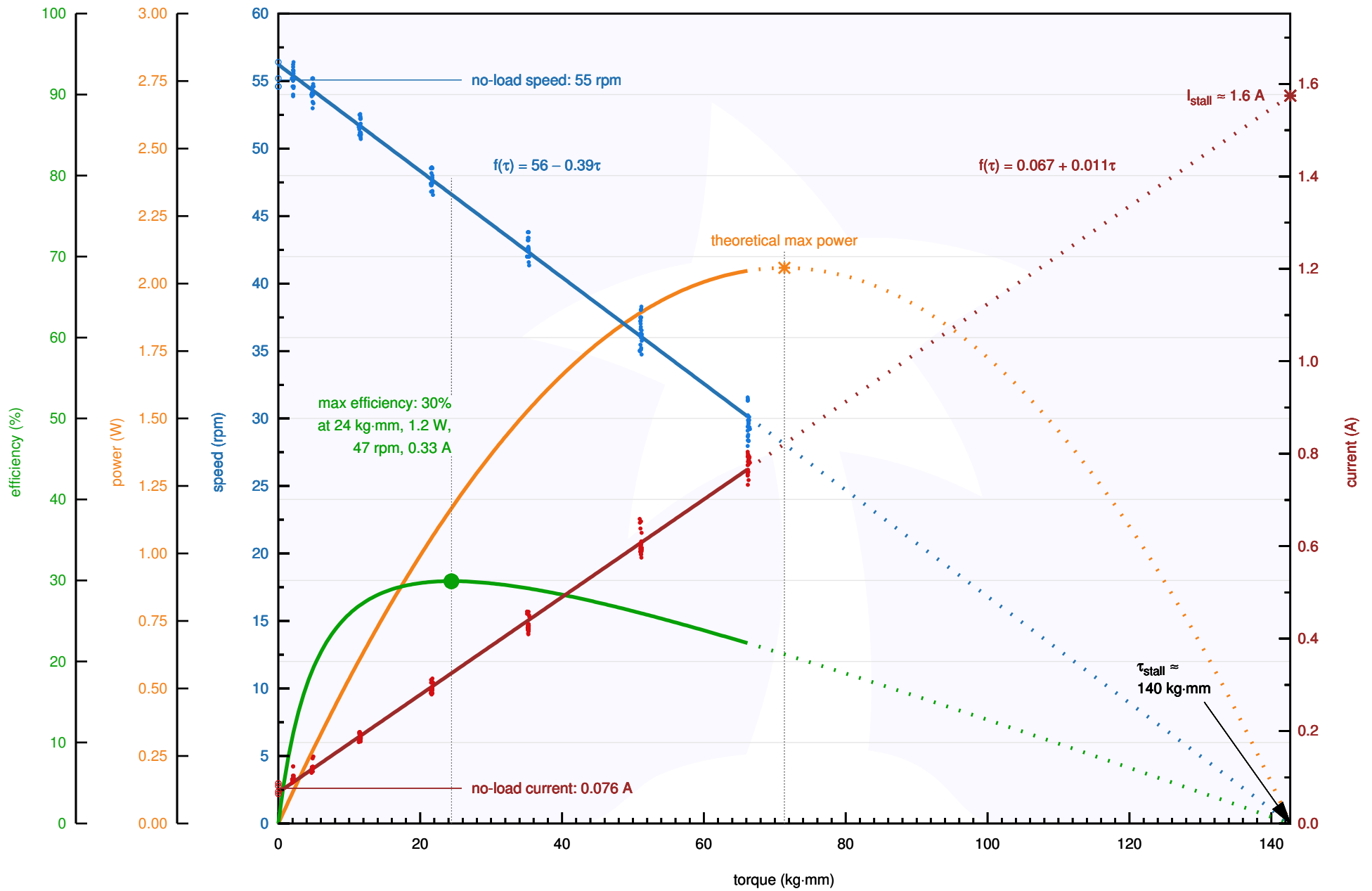

Pololu Items #3483, #3495 (313:1 Metal Gearmotor 20D 12V CB) Performance at 12 V

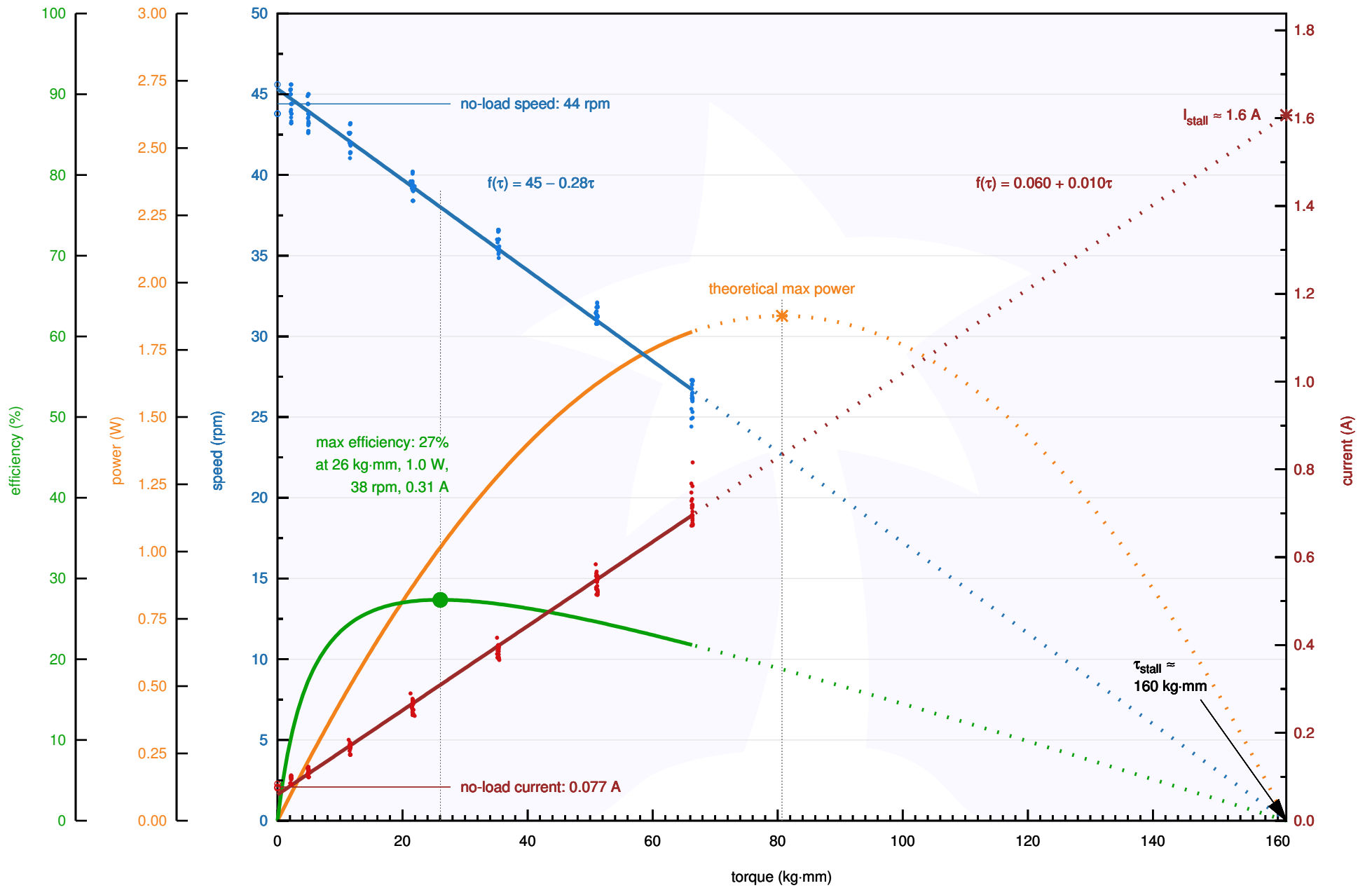

Pololu Items #3484, #3496 (391:1 Metal Gearmotor 20D 12V CB) Performance at 12 V

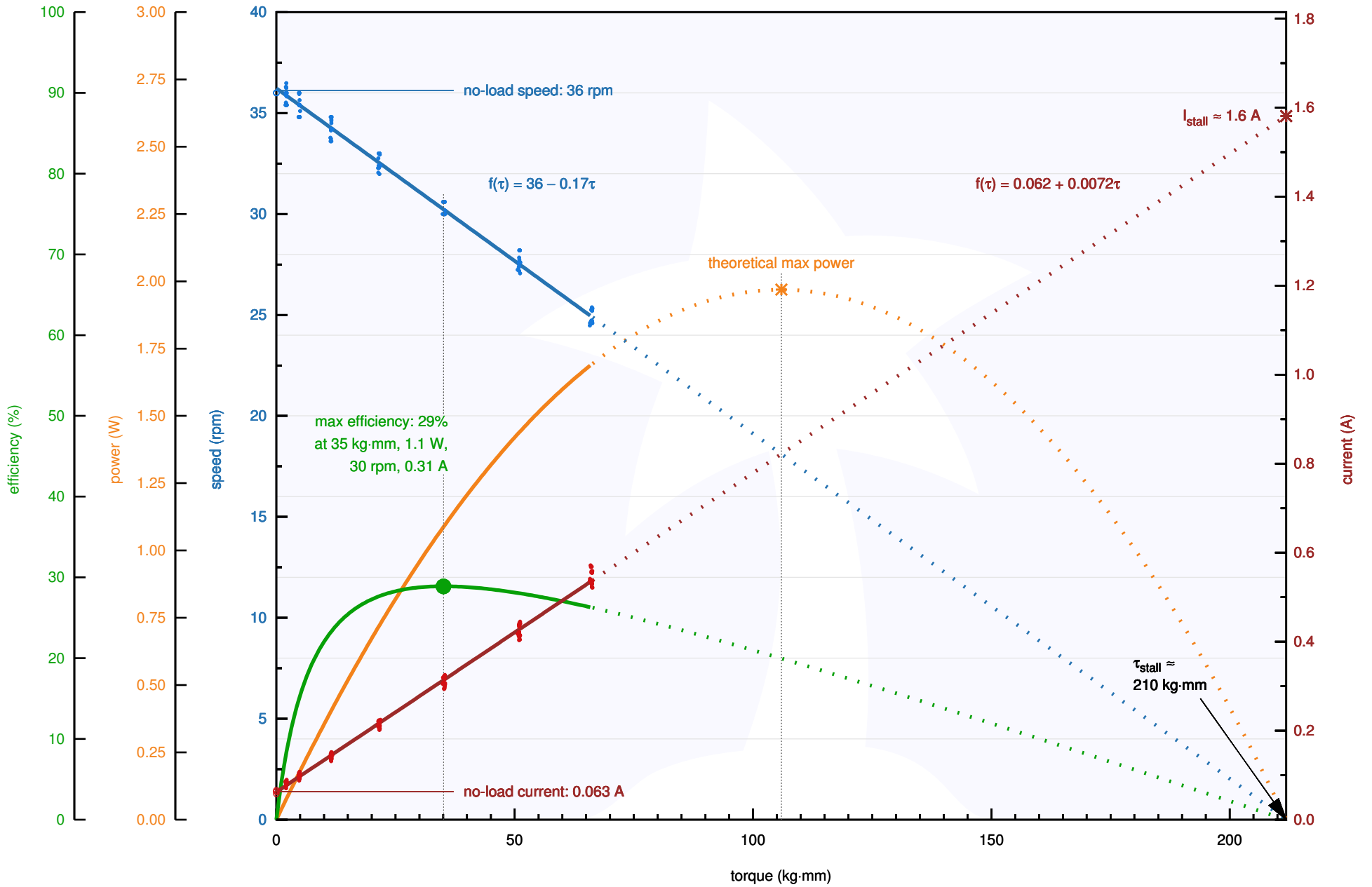

Pololu Items #3485, #3497 (488:1 Metal Gearmotor 20D 12V CB) Performance at 12 V

